

Process Display Hxdsboxai User Manual



Mechanical size: 79 × 43 × 25mm;

Installation opening: 76.5 × 39.5mm.

1. The meter can be called a universal analog input display meter. It can be matched with various sensors with analog output to display the actual physical quantity. Such as temperature transmitter, frequency converter, motor speed, pressure, liquid level, concentration, etc.
2. The instrument supports current input or voltage input.
3. Default adaptation: 0-10V, 2-10V, 0-20mA, 4-20mA. By setting the bias parameter and gain parameter, it can adapt to other inputs in the range of 0-10V, or 0-20mA.
4. It is displayed as a percentage by default. You can also set your own display range through F0-2 ~ F0-4.
5. The instrument with 485 interface has already supported the communication between the meters, and it is convenient to realize multiple displays.

Main features

1. Model description, standard version: HXDSBOXAI-NR; With RS485 version: HXDSBOXAI-485; With relay output version: HXDSBOXAI-RL
2. Standard version and version with RS485, rated power supply voltage range: DC6~25V, power consumption: 24V/40mA; with relay output version, rated power supply voltage Range: DC8~25V, power consumption: 24V/50mA; power supply anti-reverse connection and surge protection
3. 1 analog input, voltage type or current type can be selected
4. Voltage type input impedance: $>30k\Omega$, current type input impedance: $<250\Omega$
Rich parameter settings (please see the parameter description), with its own button, easily complete the parameter configuration: 0.56 inch 4-digit digital tube
5. "With RS485 version", using standard Modbus-RTU protocol, easy to achieve networking: and support networking between tables, "With relay output version", with 1 normally open relay output, relay load capacity: 3A30Dc/3A250VAC;
6. Mechanical size: 79×43×25mm: installation opening: 76.5×39.5mm.

Indicator light and signal description

1. Front panel diagram

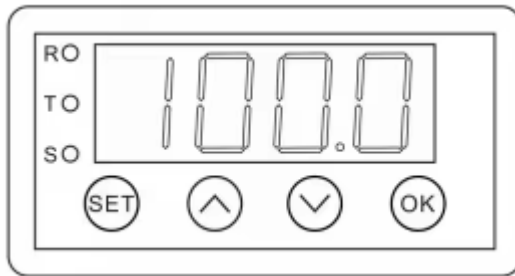

2. Indicator light:

- Only "with RS485 version" is useful: R communication receives data indication: T communication sends data indication
- Only the "with relay output version" has: S indicator light on when the relay is closed

3. Port signal description

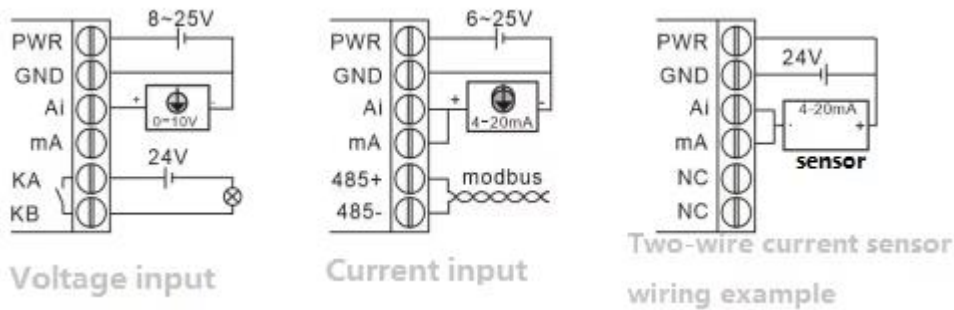

signal		Explanation
PWR		Connect to the positive pole of the power supply (standard version and version with RS485: DC6~30V: with relay output version: DC8~30V)
GND		Power and signal ground
Ai		Power and signal ground
mA		Current-type analog input signal configuration interface, short-circuited with A, then configured as current-type input
With RS485 version	485-	RS485 signal is negative
	485+	RS485 signal is positive
With relay output version	KA	Relay normally open contact output port
	KB	

4.Common wiring diagram:

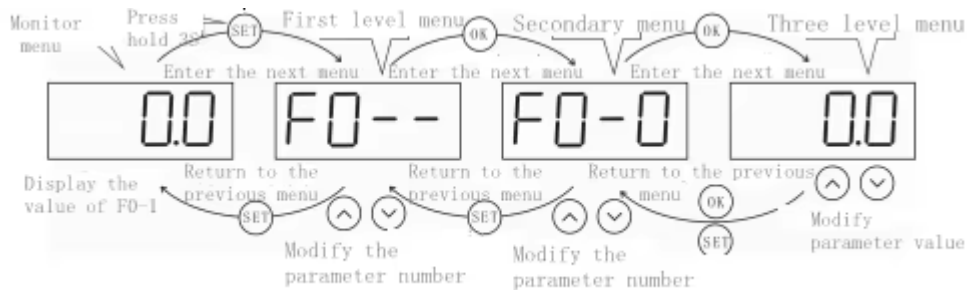

5. Button and digital tube display state transition diagram:



Special note: In the third-level menu, click OK to save the modified parameter value and return to the previous menu, the parameter number is automatically increased by one; and click the SET button to directly return to the previous menu without saving the modified parameter value .Long press  or  to make the adjustment value change quickly.

Parameter description

The parameters are described as follows:

1. F0 Attendant array display

Parameter	parameter name	Scope and description	Defaults	Read write
F0-0	Collected value monitoring	Monitor the percentage of the current analog input value. Range: 0-100.0%		read-only
F0-1	Display value monitoring	In the display value in "Monitoring Menu" is calculated by F0-0, F0-2~F04.		read-only
F0-2	Display accuracy	The number of decimal places displayed in the "Monitor Menu", range: 0-3.	1	Read write
F0-3	Show minimum	In the "monitoring menu", the value corresponding to "acquisition value" is 0%, the range: -1999~9999	0	Read write
F0-4	Show maximum	In the "Monitoring Menu", the value corresponding to the "Acquisition Value" is 100.0%, the range: 1999~9999	1000	Read write
F0-5	Offline status	0: Not disconnected; 1: Disconnected. (Disconnection detection is set by F1-4) (starting from V2.10)		read-only

2. F1 parameter group-analog configuration parameters

Parameter	parameter name	Scope and description	Defaults	Read write
F1-0	Input type selection	0: 0~10V or 0~20mA corresponds to 0~100.0%; 1: 2~10V or 4~20mA corresponds to 0~100.0%, and 0 when it is lower than 2V or 4mA.	0	Read write
F1-1	Input filter time	Analog input filter time, range: 0~10.000s. The longer the filtering time, the stronger the filtering	0.200	Read write
F1-2	Input gain	Range: 0~1000.0%.	100.0	Read write
F1-3	Input offset	-99.9~99.9%, with 10V or 20mA as 100.0%.	0.0	Read write
F1-4	Drop detection threshold	Range: 0.0-100.0%. This value is based on 0-10V or 0-20mA as 0.0-100.0% as a reference (and F1-0 and gain offset are not related), the detection is not started if it is less than 0.5, and there is a hysteresis of ± 0.3 . When the input signal is lower than this value, the meter displays E.oFL. (Starting from V2.10)	0.0	Read write
F1-5	Enter the parameter setting selection	0: Long press SET button for 3s to enter the parameter setting mode: 1: Keep pressing SET button for more than 3s, and Press OK to enter parameter setting mode	0	Read write

The analog input gain and offset use formula is: adjustment result = (collected value + offset) × gain, the adjustment result is limited to 0.0 ~ 100.0%

The range is 100.0% when greater than 100.0%, and 0.0% when less than 0.0%

3.F2 parameter group relay output dosing (with relay Output version)

Parameter	parameter name	Scope and description	Defaults	Read write
F2-0	Relay output status configuration	When the output conditions are met, the relay output status: 0: No control (always open) 1: Relay closed 2: Relay open (not satisfied Closed on condition)	0	Read write
F2-1	Condition type	0: greater than comparison value 1, 1: less than comparison value 2. 2: Greater than comparison value 1 and less than comparison value 2.	0	Read write
F2-2	Comparison value 1	Range: 0-100.0%	50.0	Read write
F2-3	Comparison value 2	Range: 0-100.0%.	50.0	Read write
F2-4	Hysteresis interval	In order to prevent the relay output from operating frequently near the comparison value, hysteresis interval parameters are introducedRange: 0.0%~80.0%.	5.0	Read write
F2-5	Relay status when offline	After setting F1-4, when the offline condition is reached, the relay output state. Note: This priority is higher than that of the comparison relay output. 0: Not used; 1: Relay is closed; 2: Relay is disconnected (starting from V2.10)	0	Read write

An example to illustrate the action mechanism of the hysteresis interval: For example, select "F2-1 condition type" as "0: greater than comparison value 1", set "F2-2 comparison value 1" to 50.0%, and use "F2-4 hysteresis interval" The default value is 5.0%. When the power is on, the collected value gradually increases. When it is greater than $50.0\% + 5.0\%/2$, the output condition is satisfied. If the collected value decreases at this time, it needs to be less than $50.0\% - 5.0\%/2$ to reach the non-output condition.

4.F7 communication parameters and software version (communication parameters are "with RS485 version" for use)

Parameter	parameter name	Scope and description	Defaults	Read write
F7-0	Local address	Range: 1~247	1	Read write
F7-1	Baud rate	0:1200bp; 1: 2400bp5; 2: 4800bps; 3: 9600bps 4:19200bps; 5: 38400bps	3	Read write
F7-2	Data Format	0:8,1, None (8 data bits, 1 stop bit, no parity) 1:8,1, Even (8 data bits, 1 stop bit, even parity) 2:8,1,Odd (8 data bits, 1 stop bit, odd parity) 3:8,2, None (8 data bits, 2 stop bits, no parity)	0	Read write
F7-3	Response delay	Communication response delay time 0~500ms	5	Read write
F7-4	Communication type	Use above V1.02 0: The display table is a Modu slave, and the user host can read the collected values of the display table: 1: The display table is a network slave between the tables, and can receive the display data of the display table set as the master: 2: The display table is the network host between the tables, and the display value is sent to the slave display table through the broadcast address 3: The display table is the inter-table networking host, and the display value is sent to the slave by means of address polling Display table, address polling range is: 1~F70 value.	0	Read write
F7-5	Parameter recovery	Set to 111 to restore the parameters to the factory settings: other values are invalid.	1313	read-only
F7-6	Model code	Module model code 0521H	0.1	
F7-7	Send interval time	The interval time for the host to send the data table during master-slave communication. Range: 0.1~100. 0s		Read write
F7-8	Software version number	Set module software version number, two decimal places. 1.00 corresponds to the software version number is v1.00		read-only

Communication protocol and communication method of "with R485 communication version"

1. The user host accesses the collected value of the display table

The communication uses the standard Modbus-RTU protocol, and reads with the multi-read instruction 03H. The return parameter value is an integer with the decimal point removed from the display value of the digital tube. For example, the display value of the F0-0 digital tube is 60.0, and it is 600 if it is read by communication. There is a one-to-one correspondence between Modbus register addresses and parameters. For example, the Modbus register address corresponding to F7-2 is 0702H, that is, the 7 in F7-2 is the high 8-bit value, and the 2 in F7-2 is the low 8-bit value.

For example, read the parameter values of parameters F0-0 and F0-1 (the F7 parameter group uses the default parameters), the format is as follows:

host sends a selective dance		Slave (HXDSB0XA1) response data	
Slave address is F7-0	01H	Slave address (F7-0)	01H
Mbus function number	03H	Modbus function number	03H
Start address (high byte)	00H	Returns the number of bytes (4 bytes)	04H
Start address (low byte)	00H	High byte of address content	02H
Read word count (high byte)	00H	low byte of the content of 000 address	58H
Read word count (low byte)	02G	High byte of 0001H address content	02H
CRC (low byte)	C4H	Low byte of 0001H address content	58H
CRC (high byte)	0BH	CRC (low byte)	7AH
		CRC (high byte)	C2H

In the above example, the read F0-0 and F0-1 are 0258H = 600, that is, the collected value F0-0 is 60.0%; the displayed value F0-1 is 60.0.

2. Networking description between tables

Through the network between the meters, the display value of the data collected by the master meter can be transmitted to the slave meter for display through RS485. There can be only one master table in a network, and there can be multiple slave tables. In use, only the master table needs to set the corresponding display range, and the slave table does not need to set the display range.

Figure 4-1: The main table sends data through broadcast mode network diagram

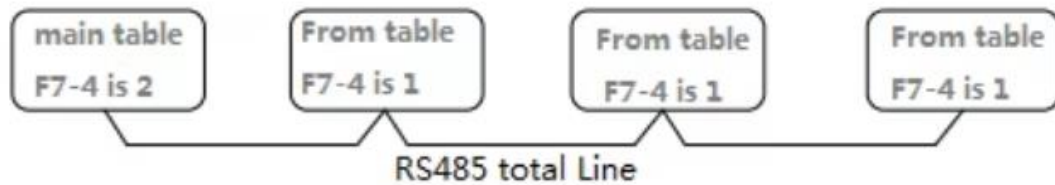
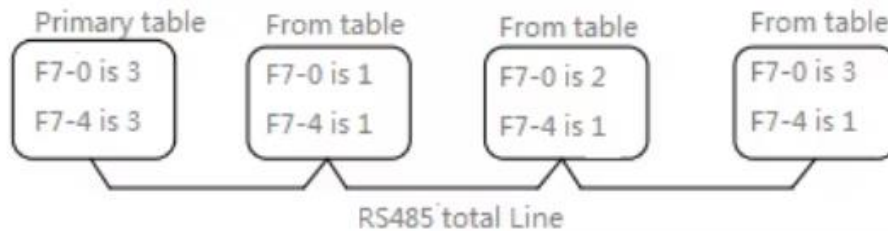

Figure 4-2: Table network diagram of sending data through address polling



The main advantages of Figure 4-1: few setting parameters, fast networking; all slave meters only need to set one parameter.

The main advantage of Figure 4-2: Because of the polling method, each slave display table can return data. It can be roughly judged by the receiving indicator of the master meter whether all slave meters are connected to the network, but each meter needs to set parameters separately.

3.Serving as a slave, used as a Modbus-RTU display meter (applicable to version V1.02 and above)

Set parameter F7-4 to 1. At this time, parameters F0-1 (corresponding to register address 01H) and F0-2 (corresponding to register address 02H) parameters can be modified through the 06H and 10H commands of the Modbus-RTU protocol (the table display is no longer analogous to Quantity collection association). The device address is still set by the F7-0 parameter. The following example assumes that F7-0 = 1, F7-4 = 1 as the premise.

- a. Write 16.88 data to the meter (that is, F0-1 is 1688, F0-2 is 2), and the meter will display 16.88 when it is received.

The host sends: 01 10 00 01 00 02 04 06 98 00 02 32 C5

Table response: 01 10 00 01 00 02 10 08

b. F0-2 is set to 1 through the panel parameters (the meter displays one decimal place), and the register address 01 (ie F0-1) is written with the function number 06H or 10H as 1234, and the meter displays 123.4.

Host send (06H write): 01 06 00 01 04 D2 5A 97

Table response (written by 06H): 01 06 00 01 04 D2 5A 97

or

Host send (10H write): 01 10 00 01 00 01 02 04 D2 25 1C

Table response (10H write): 01 10 00 01 00 01 50 09